

**JUMO GmbH & Co. KG**  
 Delivery address: Mackenrodtstraße 14  
 36039 Fulda, Germany  
 Postal address: 36035 Fulda, Germany  
 Phone: +49 661 6003-0  
 Fax: +49 661 6003-607  
 E-mail: mail@jumo.net  
 Internet: www.jumo.net

**JUMO Instrument Co. Ltd.**  
 JUMO House  
 Temple Bank, Riverway  
 Harlow, Essex CM20 2DY, UK  
 Phone: +44 1279 635533  
 Fax: +44 1279 635262  
 E-mail: sales@jumo.co.uk  
 Internet: www.jumo.co.uk

**JUMO Process Control, Inc.**  
 8 Technology Boulevard  
 Canastota, NY 13032, USA  
 Phone: 315-697-5866  
 1-800-554-JUMO  
 Fax: 315-697-5867  
 E-mail: info@jumo.us  
 Internet: www.jumo.us



# JUMO AQUIS 500 pH

## Transmitter/Controller for pH, ORP, NH<sub>3</sub> (ammonia) concentration and temperature

### Brief description

The instrument is used for measuring/controlling the pH, ORP or NH<sub>3</sub> (ammonia) concentration. The function is switchable on the instrument itself. Depending on the measured variable, combination electrodes (e. g. pH/redox combination electrodes, gas-sensitive sensors) or split versions (glass/metal electrodes with a separate reference electrode) can be readily connected. Temperature serves as the second input variable, measured by a Pt100/1000, for example. It is therefore possible to implement automatic temperature compensation for the pH and NH<sub>3</sub> variables.

The instruments are operated using unambiguous keys and a large LC graphics display on which the measurements are clearly legible. The plain-text presentation of the parameters makes it easier for the user to configure the instrument, and also helps in programming it correctly.

Thanks to its modular design, the instrument can be perfectly matched to the specific application requirements. Up to four outputs are available (see the block diagram for the functions).

### Typical areas of application

Universal application in water and wastewater engineering, service/process water and wastewater, drinking water and well/surface water, leakage monitoring in refrigeration plant

### Block diagram

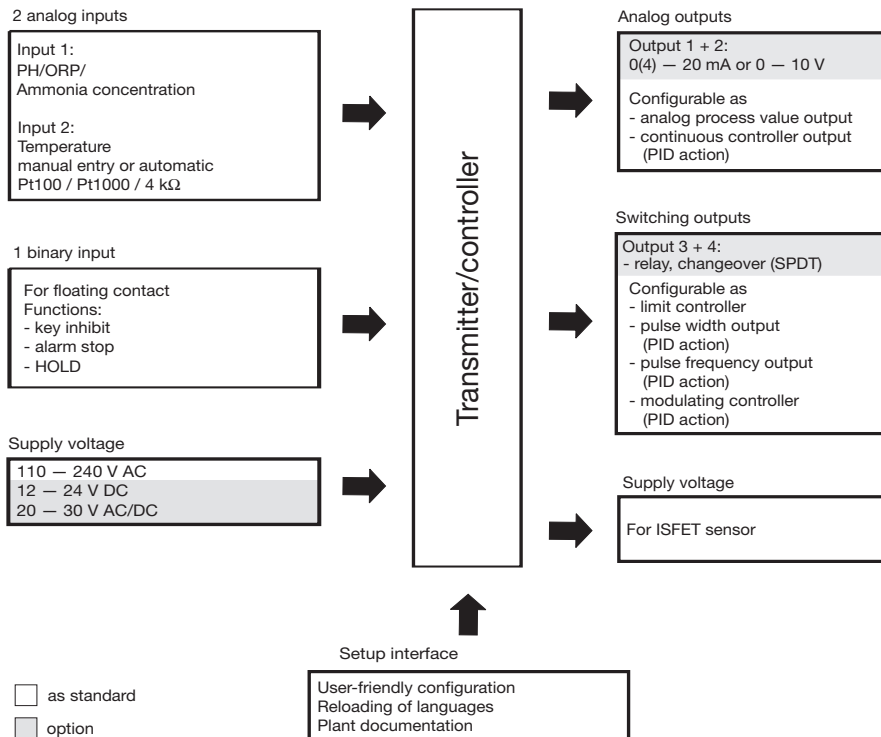

Type 202560

### Key features

- Directly switchable to pH, ORP or NH<sub>3</sub> (ammonia) concentration
- Automatic temperature compensation
- Large LC graphics display with background lighting
- Choice of display mode: large numbers, bar graph or trend display
- Solder-free connection system
- Calibration options according to measured variable: 1-/2-/3-point calibration
- Calibration logbook
- Impedance measurement can be activated for pH measurement
- Symmetrical and asymmetrical connection of pH sensors
- pH-ISFET sensors can be connected thanks to the sensor supply integrated in the output
- IP67 protection (in surface mountable housing) IP65 protection (for panel mounting)
- Language changeover: German, English, French; further languages can be loaded through the setup program
- Using the setup program: user-friendly programming, plant documentation, additional languages can be loaded

### Approvals



**JUMO GmbH & Co. KG**

Delivery address: Mackenrodtstraße 14  
36039 Fulda, Germany  
Postal address: 36035 Fulda, Germany  
Phone: +49 661 6003-0  
Fax: +49 661 6003-607  
E-mail: mail@jumo.net  
Internet: www.jumo.net

**JUMO Instrument Co. Ltd.**

JUMO House  
Temple Bank, Riverway  
Harlow, Essex CM20 2DY, UK  
Phone: +44 1279 635533  
Fax: +44 1279 635262  
E-mail: sales@jumo.co.uk  
Internet: www.jumo.co.uk

**JUMO Process Control, Inc.**

8 Technology Boulevard  
Canastota, NY 13032, USA  
Phone: 315-697-5866  
1-800-554-JUMO  
Fax: 315-697-5867  
E-mail: info@jumo.us  
Internet: www.jumo.us



## Functional description

The instrument is designed for use on site. A rugged housing protects the electronics and the electrical connections from corrosive environmental conditions (IP67). As an alternative, the instrument can also be installed in a control panel; it is then protected to IP65 at the front. The electrical connection is made by easy-to-fit pluggable screw terminals.

## Displays and controls

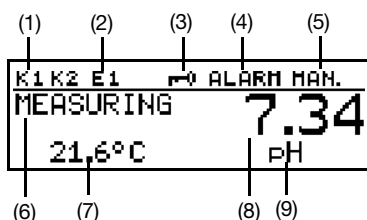

- (1) Switching output 1 or 2 is active
- (2) Binary input 1 has been actuated
- (3) Keypad is inhibited
- (4) Alarm has been activated
- (5) Instrument is in manual mode
- (6) Instrument status
- (7) Temperature of medium
- (8) Principal measurement
- (9) Unit of principal measurement

The user can define what is to be shown in positions (7) and (8) of the display:

- No display
- Compensated measurement
- Temperature
- Output level 1
- Output level 2
- Setpoint 1
- Setpoint 2

## Operation

For easy programming and operation, all parameters are arranged in clearly structured levels and shown in plain text. Operation is protected by a code word. This facilitates individual adaptation of the operation, since parameters can be generally enabled or assigned to the protected area.

As a highly convenient alternative to configuration from the keys, the instrument can also be configured through the setup program for PC (option).

## Display modes

Three display modes are available:

### Large digits

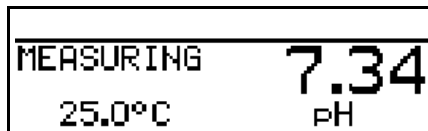

In this display mode, the measurements are, as usual, shown in digits.

### Trend display

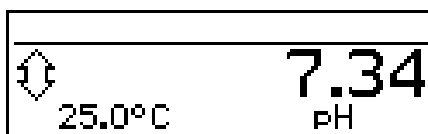

The numerical value is supplemented by a symbol which indicates the change direction and change speed of the measurement.

This can, for instance, be very useful during controller tuning.



from left to right:

fast, medium and slow rise, stable, slow, medium and fast drop.

### Bar graph

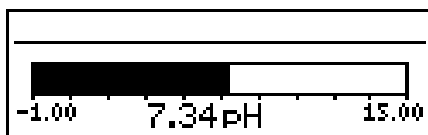

This display mode allows the user to see at a glance in which region the measurement is at present.

The bar graph can be freely scaled.

## pH measurement

Both combination pH electrodes and glass electrodes with a separate reference electrode can be connected. There are two ways of connecting the electrodes:

- asymmetrical, high-impedance (this is usual way)
- symmetrical, high-impedance (in special cases)

What is new is the possibility of monitoring the impedance of the connected electrode(s). Thanks to this feature, the glass and reference impedances can be acquired individually (when used with a separate ground pin), or as a cumulative value.

Special electrodes, which use antimony as the pH-sensitive element, can also be connected.

A supply for ISFET sensors has been integrated. This enables the user to operate suitable sensors directly.

ISFET sensors are employed for special applications where glass sensors are not required (glass-free pH measurement). However, because these sensors are not standardized, it is necessary to check their usability before application.

The pH is temperature-compensated through automatic temperature measurement, by means of the second input, or by entering the value manually.

## ORP measurement

Combination redox electrodes as well as metal electrodes with a separate reference electrode can be connected.

The value is displayed in mV, or is freely scalable.

## Ammonia measurement

After the transmitter/controller has been configured for NH<sub>3</sub> (ammonia) measurement, the appropriate sensors can be connected.

Applications:

Leakage monitoring of cooling circuits

## Calibration

### pH measurement

- 1-point calibration
- 2-point calibration
- 3-point calibration

### ORP measurement

- 1-point calibration
- with display in mV
- 2-point calibration with display in % (freely scalable)

### NH<sub>3</sub> (ammonia) measurement

- 1-point calibration (zero of electrode)

## Calibration logbook

The five most recent calibrations performed successfully can be called up in the calibration logbook. This makes it possible to evaluate the ageing of the sensor that is connected.

If required, the logbook can also be deleted (this makes sense when changing the sensor).

## Calibration timer

The calibration timer indicates (if required) when the next routine calibration is due. The calibration timer is activated by entering a number of days, after which recalibration has to be carried out (plant or operator requirement).

## Min/Max value memory

This memory acquires the minimum (bottom) or maximum (peak) input variables that have occurred. This information serves, for example, to decide whether the sensor that is connected is designed for the values that are actually present.



## Binary input

The following functions can be activated through the binary input:

- Activate key inhibit  
 When this function has been activated, operation from the keys is no longer possible.
- Activate HOLD mode  
 After activating this function, the outputs (analog and relay) adopt the states that have previously been defined.
- Alarm suppression  
 This function temporarily deactivates the alarm generation via the relay (has to be configured accordingly).

Linking the corresponding terminals by means of a floating contact (e. g. relay) will activate the pre-defined function.

## Control functions

The relays can have functions assigned that are configured via parameters. The control function is freely programmable as P, PI, PD or PID action.

## Relay outputs

One or two relay changeover (SPDT) contacts are available.

The following functions can be programmed:

- Switching direction (min/max)
- Limit controller (pull-in/drop-out delay, hysteresis)
- Pulse width output (see control functions)
- Pulse frequency output (see control functions)
- Modulating controller function (see control functions)
- Limit comparators (pull-in/drop-out delay, hysteresis)
- Pulse function  
 The output switches on in a defined way when reaching the switching point and then switches off again.

## Analog outputs

One or two analog outputs are available. The following functions can be chosen:

Output	Analog process value output		Continous controller Principle measure- ment variable
	Principle measure- ment variable	Temperature	
1	X	-	X
2	-	X	X

With the analog process value output, the range start and end values are freely selectable. The response of the outputs to over/underrange, alarm and calibration is freely programmable. Simulation function:

The analog process value outputs can be freely set in the manual ("Hand") mode. Application: "Dry-run" start-up of the plant, trouble-shooting, servicing.

- Alarm
- Sensor or range error
- Response to alarm, over/underrange, calibration and HOLD

### Contact functions

#### MAX limit function

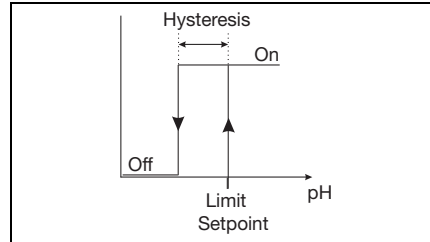

#### MIN limit function

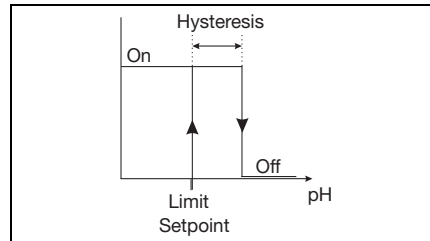

#### Alarm window 1

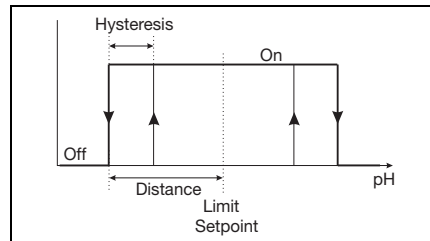

#### Alarm window 2

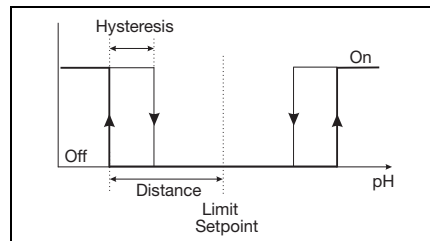

### Pulse contact

Trigger condition longer than pulse duration

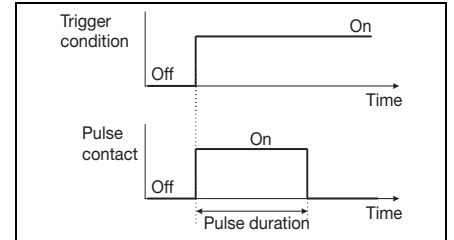

### Pulse contact

Trigger condition shorter than pulse duration

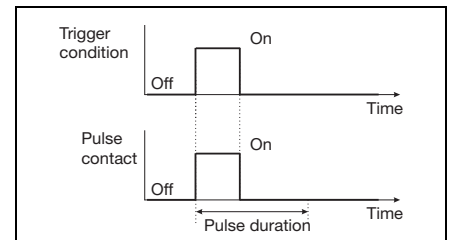

### Pulse width controller

(output is active with  $X > W$  and P action)

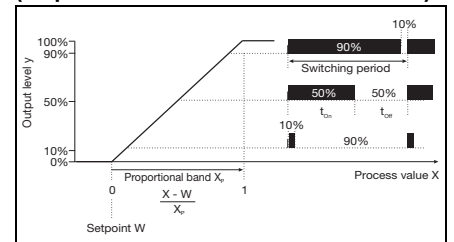

If the process value X exceeds the setpoint W, the P controller will control proportionally to the control deviation. On going outside the proportional band, the controller operates with an output level of 100% (100% duty cycle).

### Pulse frequency controller

(output is active with  $X > W$  and P action)

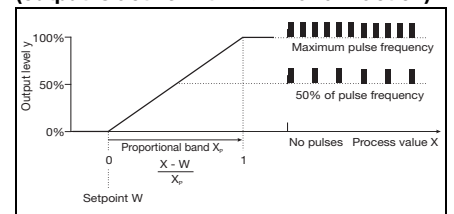

If the process value X exceeds the setpoint W, the P controller will control proportionally to the control deviation. On going outside the proportional band, the controller operates with an output level of 100% (maximum switching frequency).

**JUMO GmbH & Co. KG**  
 Delivery address: Mackenrodtstraße 14  
 36039 Fulda, Germany  
 Postal address: 36035 Fulda, Germany  
 Phone: +49 661 6003-0  
 Fax: +49 661 6003-607  
 E-mail: mail@jumo.net  
 Internet: www.jumo.net

**JUMO Instrument Co. Ltd.**  
 JUMO House  
 Temple Bank, Riverway  
 Harlow, Essex CM20 2DY, UK  
 Phone: +44 1279 635533  
 Fax: +44 1279 635262  
 E-mail: sales@jumo.co.uk  
 Internet: www.jumo.co.uk

**JUMO Process Control, Inc.**  
 8 Technology Boulevard  
 Canastota, NY 13032, USA  
 Phone: 315-697-5866  
 1-800-554-JUMO  
 Fax: 315-697-5867  
 E-mail: info@jumo.us  
 Internet: www.jumo.us



## Technical data

### Inputs

Principal input	Measurement/control range	Accuracy	Temperature error
pH	-1 to 15 pH	≤ 0.3%	0.2%/10°C
ORP	-1500 to 1500 mV	≤ 0.3%	0.2%/10°C
NH <sub>3</sub> (ammonia)	0 to 9999 ppm	≤ 0.3%	0.2%/10°C
Secondary input			
Temperature Pt100/1000 (automatic detection)	-10 to 150°C <sup>1</sup>	≤ 0.5°C	0.05%/10°C
Temperature NTC/PTC	4 kΩ max. Entry via table with 20 value pairs	≤ 0.3% <sup>2</sup>	0.05%/10°C

<sup>1</sup> Switchable to °F.

<sup>2</sup> Depending on supporting points.

### Temperature compensation

Measurement variable	Compensation	Range <sup>1</sup>
pH	yes	-10 to 150°C
ORP	no	not applicable
NH <sub>3</sub> (ammonia)	yes	-10 to 150°C

<sup>1</sup> Please note operating temperature range of sensor.

### Measuring circuit monitoring

Inputs	Over/underrange	Short-circuit	Cable break
pH	yes	yes <sup>1</sup>	yes <sup>1</sup>
ORP	yes	no	no
NH <sub>3</sub> (ammonia)	yes	no	no
Temperature	yes	yes	yes

<sup>1</sup> For pH measurement, the sensor can be monitored for short-circuit and cable break by activating the impedance measurement.

### Impedance measurement

Impedance measurement can optionally be activated.

Since it depends on some marginal parameters, the following points must be noted:

- Only glass-based sensors are permissible.
- The sensors must be directly connected to the transmitter.  
It is not permissible to use an impedance converter in the measuring circuit.
- The maximum permissible cable length between sensor and transmitter is 10 m.
- Liquid impedances will directly influence the measurement result.  
We therefore recommend activating the measurement in liquids from about 100 µS/cm upwards.

### Binary input

Activation	Through floating contact
Function	Key inhibit HOLD Alarm suppression

### Controller

Controller type	Limit comparators, limit controller, pulse width controller, pulse frequency controller, modulating controller, continuous controller
Controller action	P / PI / PD / PID
A/D converter	Dynamic resolution up to 14-bit
Sampling time	500 msec

**JUMO GmbH & Co. KG**  
 Delivery address: Mackenrodtstraße 14  
 36039 Fulda, Germany  
 Postal address: 36035 Fulda, Germany  
 Phone: +49 661 6003-0  
 Fax: +49 661 6003-607  
 E-mail: mail@jumo.net  
 Internet: www.jumo.net

**JUMO Instrument Co. Ltd.**  
 JUMO House  
 Temple Bank, Riverway  
 Harlow, Essex CM20 2DY, UK  
 Phone: +44 1279 635533  
 Fax: +44 1279 635262  
 E-mail: sales@jumo.co.uk  
 Internet: www.jumo.co.uk

**JUMO Process Control, Inc.**  
 8 Technology Boulevard  
 Canastota, NY 13032, USA  
 Phone: 315-697-5866  
 1-800-554-JUMO  
 Fax: 315-697-5867  
 E-mail: info@jumo.us  
 Internet: www.jumo.us



### Analog outputs (one or two)

Output mode	Signal range	Accuracy	Temperature error	Permissible load resistance
Current signal	0/4 – 20 mA	≤ 0.25%	0.08%/10 °C	≤ 500Ω
Voltage signal	0 – 10 V	≤ 0.25%	0.08%/10 °C	≥ 500 Ω

The analog outputs respond as per NAMUR NE43 recommendation.  
 They are electrically isolated, 30 V AC / 50 V DC.

### Switching outputs (two changeover (SPDT) max.)

<b>Rated load</b>	3 A/250 VAC (resistive load)
<b>Contact life</b>	>2x10 <sup>5</sup> operations at rated load

### Supply for ISFET

±5 V DC; 5 mA

### Setup interface

Interface for configuring the instrument through the optionally available setup program (for instrument configuration only).

### Electrical data

<b>Supply voltage</b>	AC 110 – 240 V, -15/+10%, 48 – 63 Hz AC/DC 20 – 30 V, 48 – 63 Hz DC 12 – 24 V, +/-15% (permissible only for connection to SELV/PELV circuits)
<b>Power consumption</b>	approx. 14 VA
<b>Electrical safety</b>	EN 61 010, Part 1 overvoltage category III <sup>1</sup> , pollution degree 2
<b>Data backup</b>	EEPROM
<b>Electrical connection</b>	pluggable screw terminals conductor cross-section up to 2.5 mm <sup>2</sup> (supply, relay outputs, sensor inputs) conductor cross-section up to 1.5 mm <sup>2</sup> (analog outputs; ISFET supply)

<sup>1</sup> Not valid with protective extra-low voltage of power supply variant 12 – 24 V DC.

### Housing

<b>Material</b>	ABS
<b>Cable entry</b>	cable glands, 3xM16 and 2xM12 max.
<b>Special feature</b>	venting device to prevent condensation
<b>Ambient temperature range</b> (the accuracy specified is adhered to within this range)	-10 to 50°C
<b>Operating temperature range</b> (instrument is operational)	-15 to 65°C
<b>Storage temperature range</b>	-30 to 70°C
<b>Climatic conditions</b>	rel. humidity ≤ 90% annual mean, no condensation (following EN 60721 3-3 3K3)
<b>Enclosure protection</b> as per EN 60529	in surface mountable housing: IP67 for panel mounting: IP65 front, IP20 rear
<b>Vibration strength</b>	as per EN 60068-2-6
<b>Weight</b>	in surface mountable housing: approx. 900 g for panel mounting: approx. 480 g
<b>Dimensions</b>	see dimensioned drawings on page 8.

### Standard accessories

Cable glands  
 Internal mounting material  
 Operating Instructions

**JUMO GmbH & Co. KG**

Delivery address: Mackenrodtstraße 14  
 36039 Fulda, Germany  
 Postal address: 36035 Fulda, Germany  
 Phone: +49 661 6003-0  
 Fax: +49 661 6003-607  
 E-mail: mail@jumo.net  
 Internet: www.jumo.net

**JUMO Instrument Co. Ltd.**

JUMO House  
 Temple Bank, Riverway  
 Harlow, Essex CM20 2DY, UK  
 Phone: +44 1279 635533  
 Fax: +44 1279 635262  
 E-mail: sales@jumo.co.uk  
 Internet: www.jumo.co.uk

**JUMO Process Control, Inc.**

8 Technology Boulevard  
 Canastota, NY 13032, USA  
 Phone: 315-697-5866  
 1-800-554-JUMO  
 Fax: 315-697-5867  
 E-mail: info@jumo.us  
 Internet: www.jumo.us

**Approvals/marks of conformity**

Mark of conformity	Testing laboratory	Certificates/certification numbers	Test basis	valid for
c UL us	Underwriters Laboratories	E 201387	UL 61010-1	all types

**JUMO GmbH & Co. KG**  
 Delivery address: Mackenrodtstraße 14  
 36039 Fulda, Germany  
 Postal address: 36035 Fulda, Germany  
 Phone: +49 661 6003-0  
 Fax: +49 661 6003-607  
 E-mail: mail@jumo.net  
 Internet: www.jumo.net

**JUMO Instrument Co. Ltd.**  
 JUMO House  
 Temple Bank, Riverway  
 Harlow, Essex CM20 2DY, UK  
 Phone: +44 1279 635533  
 Fax: +44 1279 635262  
 E-mail: sales@jumo.co.uk  
 Internet: www.jumo.co.uk

**JUMO Process Control, Inc.**  
 8 Technology Boulevard  
 Canastota, NY 13032, USA  
 Phone: 315-697-5866  
 1-800-554-JUMO  
 Fax: 315-697-5867  
 E-mail: info@jumo.us  
 Internet: www.jumo.us



## Electrical connection

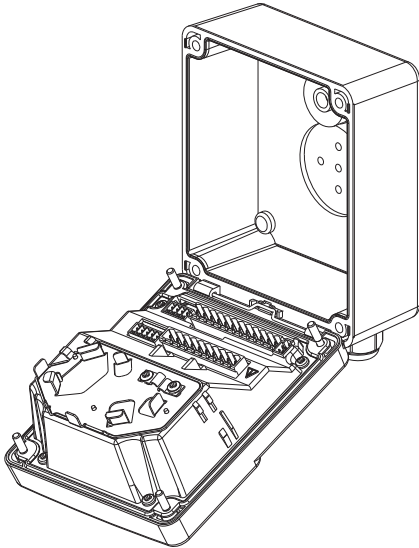

The electrical connection for the “in surface mountable housing” version can be made easily after opening the unit.

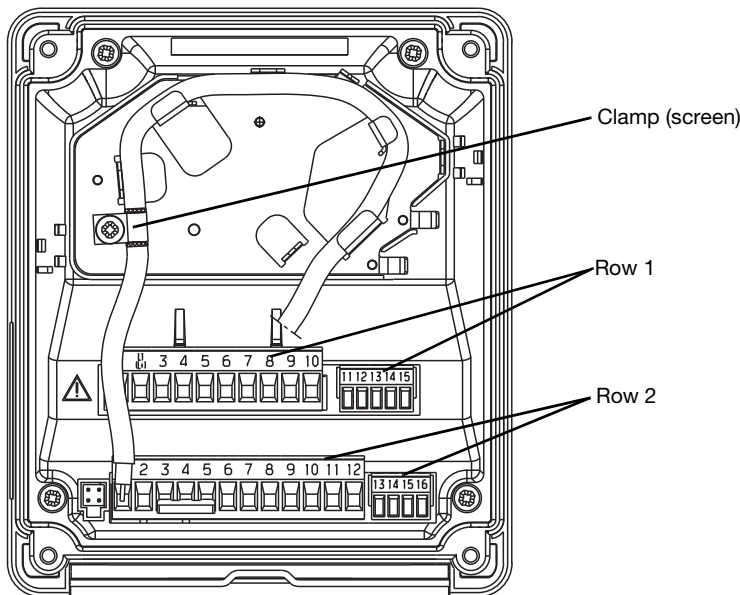

The connection cable between sensor and transmitter must be a special coaxial cable with a diameter of 3 to 5 mm (e. g. 2992-2(x)-0).

The instrument contains a guide plate for optimized cable routing.

The sensor cables (incorporating strain relief) are run to the pluggable screw terminals, where they are connected up without the use of solder.

Connection		Terminal	Row
<b>Supply for transmitter/controller</b>			
Supply voltage (23): AC 110 – 230 V, -15/+10%, 48 – 63 Hz		1 N (L-)	1
Supply voltage (25): AC/DC 20 – 30 V, 48 – 63 Hz		2 L1 (L+)	
Supply voltage (30): DC 12 – 24 V, +/-15%			
NC		3	
<b>Supply voltage for ISFET sensor</b>			
Supply voltage ± 5 V DC, 5 mA		11 L+	1
		12 L	
		13 L-	
NC		14	
NC		15	

**JUMO GmbH & Co. KG**  
 Delivery address: Mackenrodtstraße 14  
 36039 Fulda, Germany  
 Postal address: 36035 Fulda, Germany  
 Phone: +49 661 6003-0  
 Fax: +49 661 6003-607  
 E-mail: mail@jumo.net  
 Internet: www.jumo.net

**JUMO Instrument Co. Ltd.**  
 JUMO House  
 Temple Bank, Riverway  
 Harlow, Essex CM20 2DY, UK  
 Phone: +44 1279 635533  
 Fax: +44 1279 635262  
 E-mail: sales@jumo.co.uk  
 Internet: www.jumo.co.uk

**JUMO Process Control, Inc.**  
 8 Technology Boulevard  
 Canastota, NY 13032, USA  
 Phone: 315-697-5866  
 1-800-554-JUMO  
 Fax: 315-697-5867  
 E-mail: info@jumo.us  
 Internet: www.jumo.us



Connection		Terminal	Row
<b>Inputs</b>			
Glass/metal electrode		1	2
NC		2	
Reference electrode		3	
NC		4	
GND		5	
Link terminal 3 and terminal 5 (asymmetrical connection only)		6	
FP (liquid potential) For connection with symmetrical connection only		7	
NC		8	
RTD in 3-wire circuit, Pt100 or Pt1000		9 10	
Binary input		11 12	
<b>Outputs</b>			
Analog output 1 0 – 20 mA or 20 – 0 mA or 4 – 20 mA or 20 – 4 mA or 0 – 10 V or 10 – 0 V (electrically isolated)		+ 13 - 14	2
Analog output 2 0 – 20 mA or 20 – 0 mA or 4 – 20 mA or 20 – 4 mA or 0 – 10 V or 10 – 0 V (electrically isolated)		+ 15 - 16	
Switching output K1 (floating)		4 common 5 break (SPST-NC) 6 make (SPST-NO)	1
NC		7	
Switching output K2 (floating)		8 common 9 break (SPST-NC) 10 make (SPST-NO)	



**JUMO GmbH & Co. KG**  
 Delivery address: Mackenrodtstraße 14  
 36039 Fulda, Germany  
 Postal address: 36035 Fulda, Germany  
 Phone: +49 661 6003-0  
 Fax: +49 661 6003-607  
 E-mail: mail@jumo.net  
 Internet: www.jumo.net

**JUMO Instrument Co. Ltd.**  
 JUMO House  
 Temple Bank, Riverway  
 Harlow, Essex CM20 2DY, UK  
 Phone: +44 1279 635533  
 Fax: +44 1279 635262  
 E-mail: sales@jumo.co.uk  
 Internet: www.jumo.co.uk

**JUMO Process Control, Inc.**  
 8 Technology Boulevard  
 Canastota, NY 13032, USA  
 Phone: 315-697-5866  
 1-800-554-JUMO  
 Fax: 315-697-5867  
 E-mail: info@jumo.us  
 Internet: www.jumo.us



## Dimensions

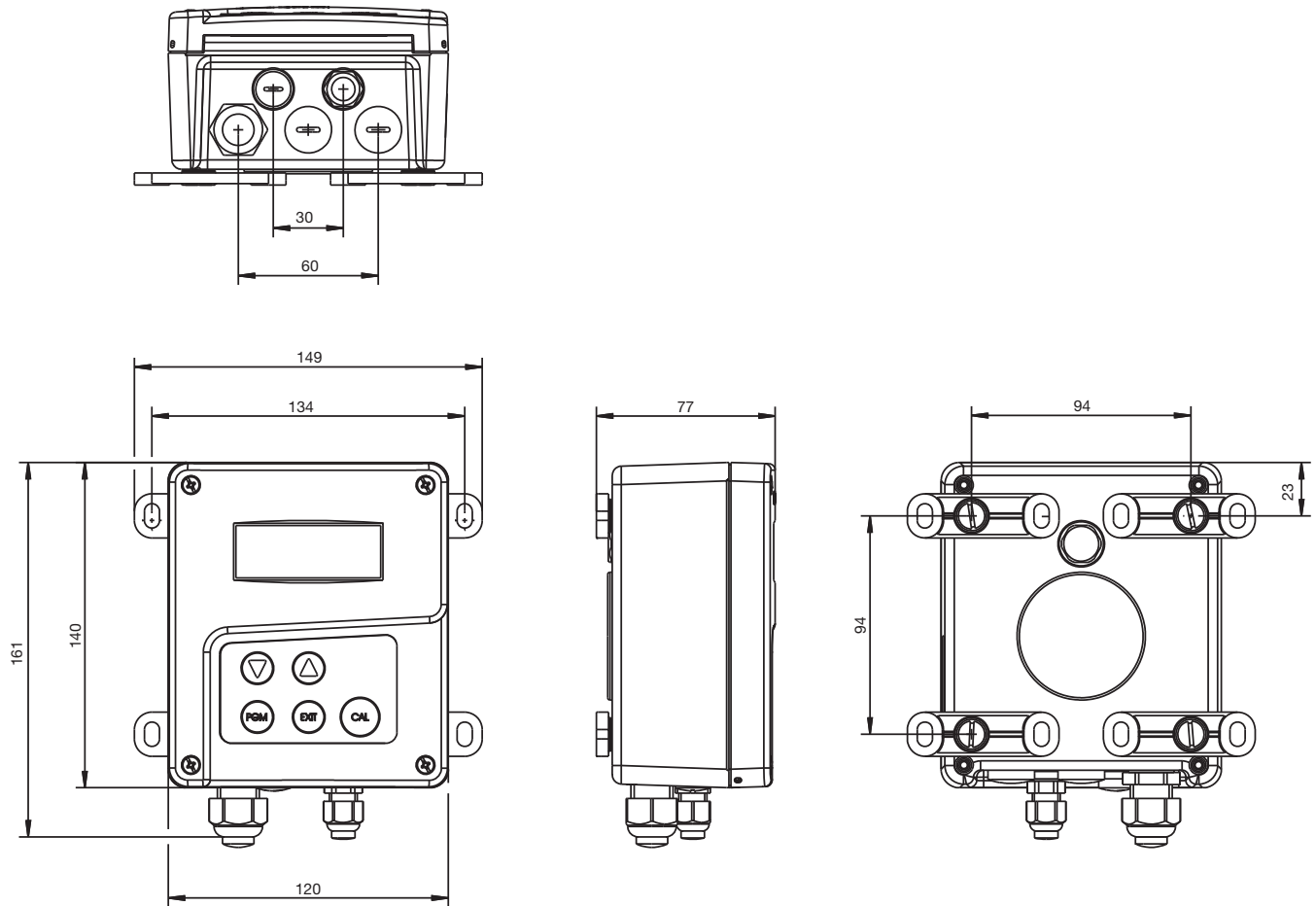

## Panel-mounting/drilling diagram

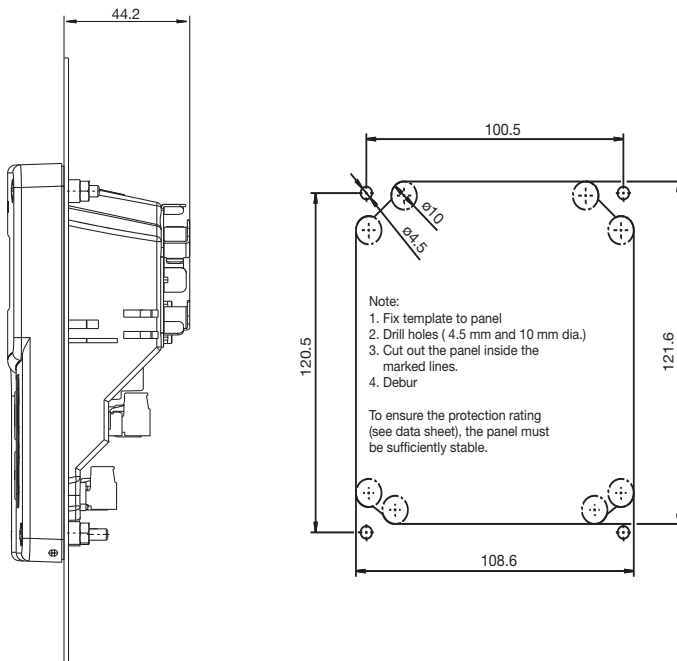

**Note:**  
 The drilling template (in actual size) is shown in the Operating Instructions B 202560.0.

**JUMO GmbH & Co. KG**  
Delivery address: Mackenrodtstraße 14  
36039 Fulda, Germany  
Postal address: 36035 Fulda, Germany  
Phone: +49 661 6003-0  
Fax: +49 661 6003-607  
E-mail: mail@jumo.net  
Internet: www.jumo.net

**JUMO Instrument Co. Ltd.**  
JUMO House  
Temple Bank, Riverway  
Harlow, Essex CM20 2DY, UK  
Phone: +44 1279 635533  
Fax: +44 1279 635262  
E-mail: sales@jumo.co.uk  
Internet: www.jumo.co.uk

**JUMO Process Control, Inc.**  
8 Technology Boulevard  
Canastota, NY 13032, USA  
Phone: 315-697-5866  
1-800-554-JUMO  
Fax: 315-697-5867  
E-mail: info@jumo.us  
Internet: www.jumo.us



**Accessories**

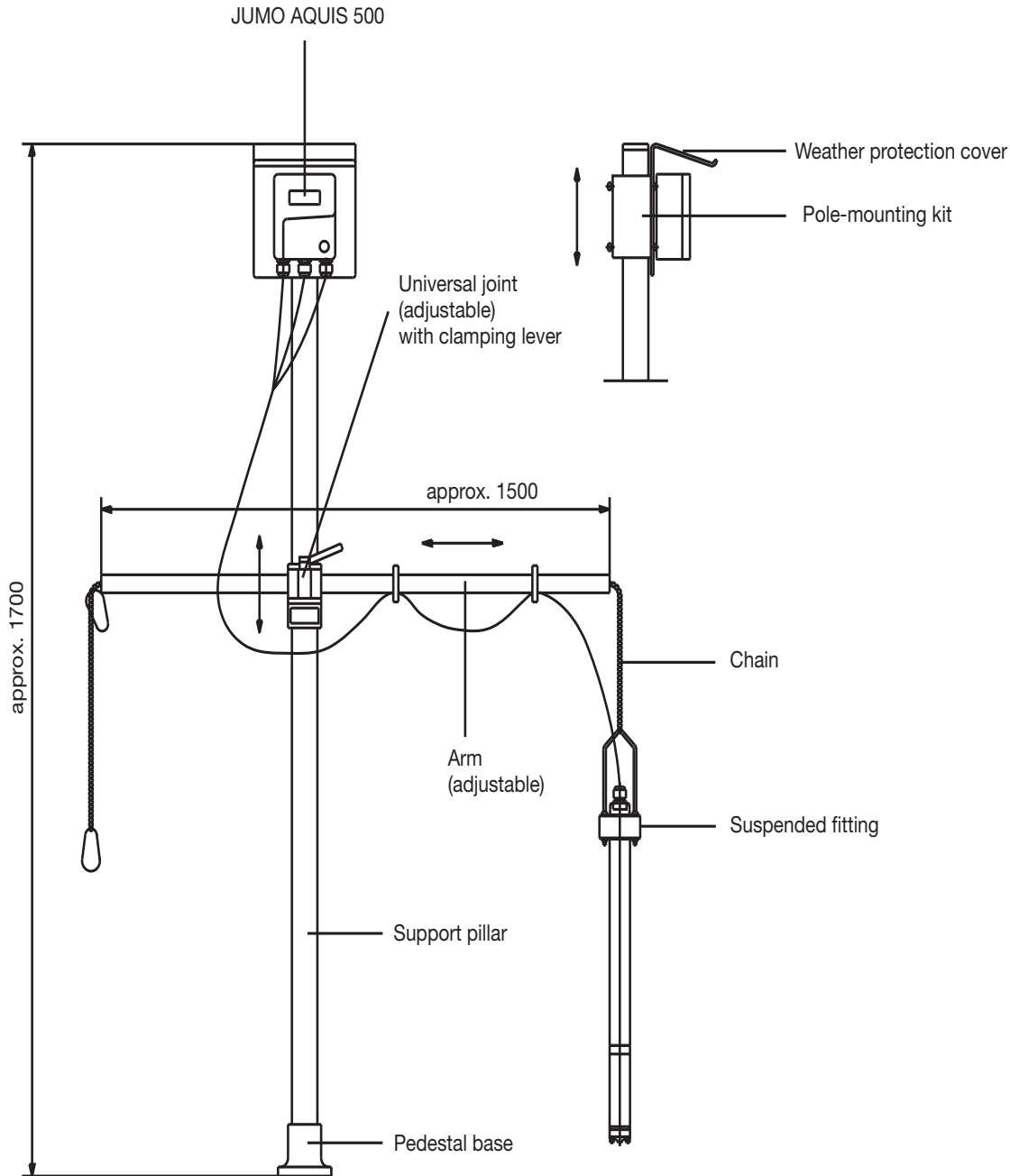

**JUMO GmbH & Co. KG**  
 Delivery address: Mackenrodtstraße 14  
 36039 Fulda, Germany  
 Postal address: 36035 Fulda, Germany  
 Phone: +49 661 6003-0  
 Fax: +49 661 6003-607  
 E-mail: mail@jumo.net  
 Internet: www.jumo.net

**JUMO Instrument Co. Ltd.**  
 JUMO House  
 Temple Bank, Riverway  
 Harlow, Essex CM20 2DY, UK  
 Phone: +44 1279 635533  
 Fax: +44 1279 635262  
 E-mail: sales@jumo.co.uk  
 Internet: www.jumo.co.uk

**JUMO Process Control, Inc.**  
 8 Technology Boulevard  
 Canastota, NY 13032, USA  
 Phone: 315-697-5866  
 1-800-554-JUMO  
 Fax: 315-697-5867  
 E-mail: info@jumo.us  
 Internet: www.jumo.us



**Order details: JUMO AQUIS 500 pH**

- (1) Basic type**  
 JUMO AQUIS 500 pH  
 202560 Transmitter/controller for pH, ORP,  
 NH<sub>3</sub> (ammonia) concentration and temperature
- (2) Basic type extensions**  
 10 for panel mounting  
 20 in surface mountable housing
- (3) Output 1 (for principle measurement variable or continuous controller)**  
 000 no output  
 888 analog output 0(4) – 20 mA or 0(2) – 10 V
- (4) Output 2 (for principle measurement variable or continuous controller)**  
 000 no output  
 888 analog output 0(4) – 20 mA or 0(2) – 10 V
- (5) Output 3**  
 000 no output  
 310 relay with changeover (SPDT) contact
- (6) Output 4**  
 000 no output  
 310 relay with changeover (SPDT) contact
- (7) Supply voltage**  
 25 20 – 30 V AC/DC, 48 – 63 Hz<sup>1</sup>  
 23 110 – 240 V AC + 10% / -15%, 48 – 63 Hz  
 30 12 – 24 V DC ± 15%<sup>1</sup>
- (8) Extra codes**  
 000 none

**Order code**                    (1)                    (2)                    (3)                    (4)                    (5)                    (6)                    (7)                    (8)  
 Order example                202560 / 20 - 888 - 000 - 310 / 000 - 23 / 000, ...<sup>2</sup>

**Stock items** (shipment: 3 working days after receipt of order)

Type	Part no.
202560/20-888-888-310-310-23/000	00480051
202560/20-888-000-310-000-23/000	00480050

**Production items** (shipment: 10 days after receipt of order)

Type	Part no.
202560/10-888-888-310-310-23/000	00480048
202560/10-888-000-310-000-23/000	00480044
202560/20-888-888-310-310-25/000 <sup>1</sup>	00480049

**Accessories** (shipment: 10 days after receipt of order)

Type	Part no.
Protective roof for JUMO AQUIS 500 <sup>1</sup>	00398161
Pipe installation set for JUMO AQUIS 500 <sup>2</sup>	00483664
DIN rail installation set for JUMO AQUIS 500 <sup>3</sup>	00477842
Support pillar with base clamp, arm and chain	00398163
Holder for suspension fitting	00453191
Back panel set 202560/65	00506351
PC setup software	00483602
PC interface cable including USB/TTL converter and two adapters (USB connecting cable)	00456352

<sup>1</sup> The pole-mounting kit is needed for mounting the protection cover.  
<sup>2</sup> With the pipe installation set, the JUMO AQUIS 500 can be attached to a pipe (e. g. a support pillar or a railing).  
<sup>3</sup> With the DIN rail installation set, the JUMO AQUIS 500 can be attached to a 35 mm x 7.5 mm DIN rail as per EN 60715 A.1.